

ART range

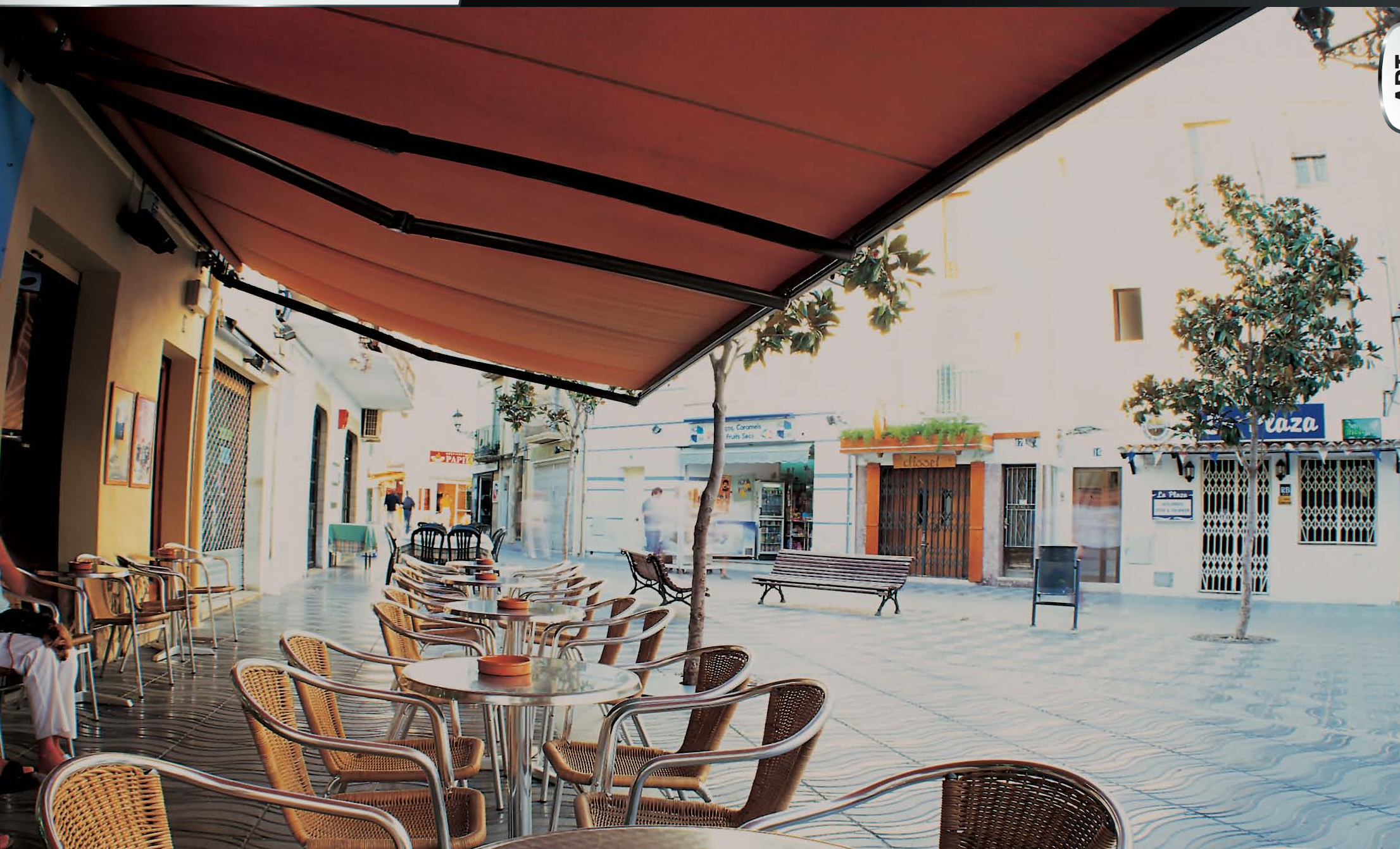

ART MONOBLOC 500

The perfect awning for large terraces



ART

Description

This is an invisible arm range awning designed to cover large areas. With a projection of 5 metres this awning can cover up to 60 m² without the need for pillars or other obstacles.

Ideal for installation

- On café terraces
- In restaurants
- Any other large area

Dimensions

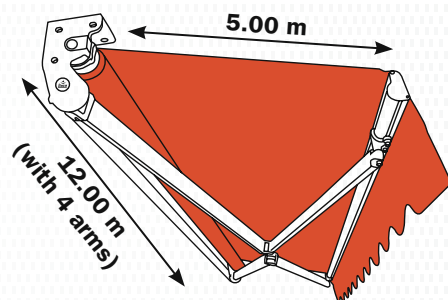

Mounting

- Wall Monobloc
- Ceiling Monobloc



The brackets are mounted on a 50x50x3 reinforced square bar in order to simplify operation, reduce set up time and make the system safer.

The tension transmission system

ART 500 arms with the ART SYSTEM internal tension transmission help to ensure that the lacquer is not damaged and notably lengthen the lifespan of the awning.



Operation

- Motorised or automated with wind sensor



Finishes

- Lacquer in accordance with QUALICOAT standards
- Stainless steel screws and bolts



European standard classification: Class 2



Accessories

- Galaxia weather cover



Technical specifications

Dimensions (mm)	
Wall	Ceiling

Roller capacity	
With ø80 tube	5.00 m

Degree of inclination	
Wall mounting	Ceiling mounting

Maximum width according to maximum projection		
With 2 arms	With 3 arms	With 4 arms
6.50 m	9.00 m	12.00 m

Minimum arm width with ART Monobloc 500			
Projection	N° of arms		
	2	3	4
4.00 m	5.00 m	7.40 m	9.90 m
4.50 m	5.50 m	8.15 m	10.90 m
5.00 m	6.00 m	8.90 m	11.90 m

Features:

- Up to 5 metres of projection with all the durability and safety needed for a system of this size.
- The great widths this system can cover; with only one set of arms, it can extend to a width of up to 6.5 metres, and with additional sets of arms and anchors it can be extended to a maximum of 12 metres.

